

A - A

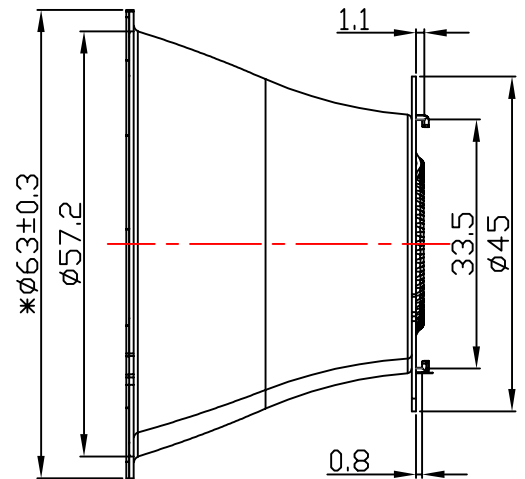

Light Source	LUMILEDS 1205
PlasticHolder	92.70.411.00
Metal Adaptor	
Design Angle	$18^\circ \pm 3^\circ$
Measured Angle	19.4°
Efficiency	

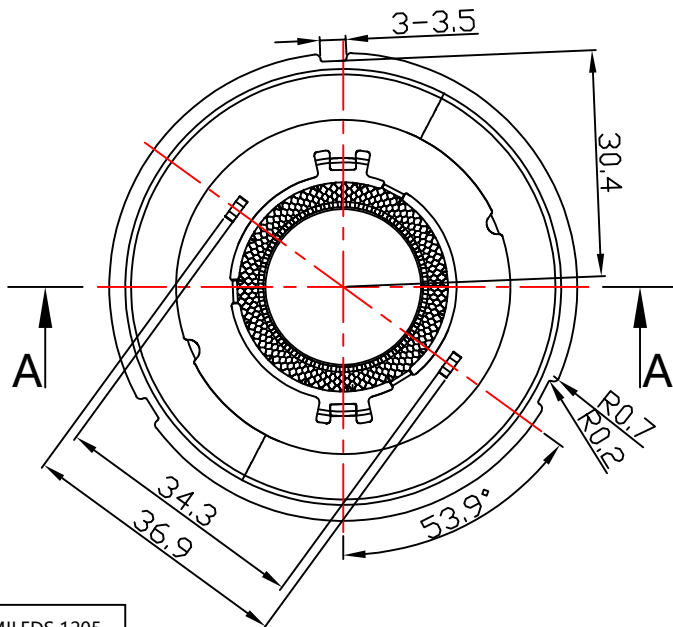
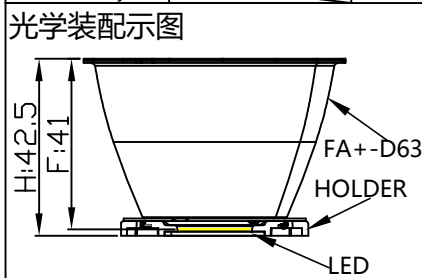

Technical requirements:

- 1.**KEY CONTROL DIMENSION.
- 2.Tolerances not noted are in accordance with the tolerance table.
- 3.unmarked rounded corners Press for 3D.
- 4.Surface without imprint, black spots, cracks, wrinkles and other poor.

PRODUCT BOM				
NO.	PRODUCT NAME	P/N:	QUANTITY	MATERIAL/FINISH
①	2-2641-L卡扣	97.77.073.00	1	T=0.6mm SUS301
②	2-2560-A	94.02.2560.000	1	T=0.6mm 1070AL/Andoizing
③	2-2561-A	94.02.2561.000	1	T=0.4mm High reflectivity aluminum(Mirror surface)

标记 MARK	处数 NO.OF MODIF	更改内容 MODIFICATIONS	签名 SIGNED BY	更改日期 MODIF. DATE
设计 DESIGNER	制图 DRAWN BY	审核 CHECKED BY	比例 SCALE	1:1
工艺 TECHNICIAN	日期 DATE(DD-MM-YYYY)	12-07-2022	视角 1st ANGLE PROJECTION	
批准 APPROVED BY	日期 DATE(DD-MM-YYYY)	12-07-2022	页数 PAGE	SHEET 1 OF 1

DIMENSION TOLERANCE TABLE (UNLESS OTHERWISE STATED)						
> 0-5	> 5-30	> 30-90	> 90-150	> 150-250	> 250-400	> 400-700
±0.15	±0.2	±0.4	±0.5	±0.8	±1.5	±2

PUNCH TOLERANCE TABLE (UNLESS OTHERWISE STATED) (ANGLE)				
> 0-10	> 10-50	> 50-120	> 120-250	> 250-360
±1°	±0.5°	±0.3°	±0.2°	±0.166°

Nata® 版本 K

产品编码
PRODUCT CODE: 91.02.2639.000

产品名称
PRODUCT NAME: 2-2639-L

客户代号
CUSTOMER ID: NT

客户编号
CUSTOMER CODE: FA+-63-18D

单位
UNIT: mm

产品图
PRODUCT DRAWING